

Brandt

**BUILT IN GAS HOB
USER MANUAL
INSTALLATION INSTRUCTION**

**TG2282BE#
TG2283BE#
TG2293BE#**

To avoid the risk of accidents or damage to the appliance.
It is essential to read these instructions before
it is installed or used for the first time.

TABLE OF CONTENTS

• SAFETY: READ THIS FIRST!	2
• FROM THE MANUFACTURER	2
• COMPONENT INFORMATION	3
• DESCRIPTION OF APPLIANCES	4
• MAINTAINING YOUR COOKTOP	4
• PRACTICAL ADVISE	6
• EASE OF USE	6 - 7
• INSTALLATION REQUIREMENT	7 – 8
• INSTALLATION PROCEDURE	8 – 12
• GAS CONNECTIONS	12 – 13
• ELECTRICAL CONNECTION	14
• GAS CONVERSION	15
• TROUBLESHOOTING	16

SAFETY: READ THIS FIRST!

- Check the appliance for damage before and after unpacking it.
- Read this user manual thoroughly before attempting to use this appliance.
- The appliance should be correctly installed according to the provided safety instruction by a qualified installer. The installer is responsible for ensuring that the appliance works correctly at its installation location. BRANDT is not liable for damage caused by incorrect installation or connection by any unauthorized technician, and such damages are not covered under warranty.
- It is dangerous to modify any part of this appliance.
- To avoid a hazard, contact only the Brandt After Sales department, its service agent to avoid mishandling.
- Always use authentic Replacement Parts.
- BRANDT is not liable for damages in case of failure to adopt proper safety measures.
- Ensure the location in which this appliance is installed is well ventilated.
- The use of a gas-powered cooking appliance generates heat, moisture, and combustion byproducts "within the space where it is installed. Ensure adequate ventilation in the kitchen, especially when the appliance is in use: maintain natural ventilation holes open or install mechanical ventilation (mechanical extractor hood).
- This appliance is intended solely for cooking. It cannot be used for other purposes, such as room heating.
- In case of tempered glass breakage:
 - Immediately turn off all burners and any electrical heating elements and disconnect the appliance from the power supply.
 - Do not touch the appliance surface.
 - Do not use the appliance.
- The following should be avoided:
 - Using unstable or deformed cookware.
 - Improper and/or dangerous use.
 - Exposure to atmospheric agents (rain, sun).
 - Using flammable liquids nearby.

FROM THE MANUFACTURER

- This appliance and its packaging are produced by processes that minimize waste and respect the environment.
- Please assist us in continuing to protect the environment by disposing of the packaging properly.

SAFETY!

- Young children are not permitted to play with the plastic bag packaging.
- Before discarding old appliances, be sure to disconnect the power cord so that others are not endangered by a faulty electrical appliance.
- The assistance of qualified personnel must be called upon in the following cases:
 - Installation (in accordance with the manufacturer's instructions)
 - When in doubt about the operation of the appliance.
- Only use the appliance to cook food, avoiding all other uses.
- Check the condition of the appliance after it has been unpacked.
- When not in use, remove the battery and turn off the gas valve (if present).
- Always check to make sure that the control knobs are on the "•"/"o" setting when the appliance is not in use.

COMPONENT INFORMATION

- A. Wok Burners
- B. Auxiliary Burner
- C. Support Grids for Cookware
- D. Control Knobs for Gas Burners
- E. Ignitor for Gas Burners
- F. Flame Failure Device



TG2282BE#

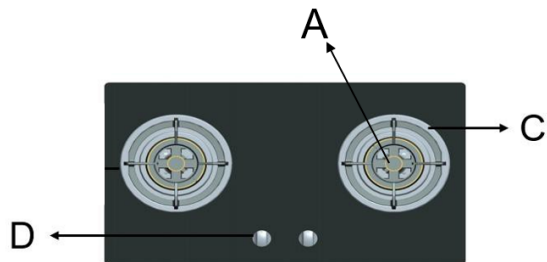

TG2283BE#
TG2293BE#

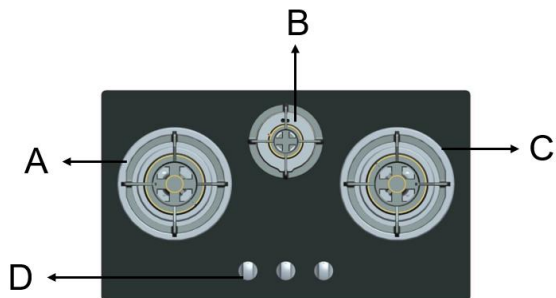

TROUBLESHOOTING

It is possible for the cooktop to not function or to function improperly. Before contacting customer service for assistance, let's examine our options. First, ensure that the gas and battery supplies are not interrupted, and that the main gas valves are open.

Symptoms	Actions
The burner does not ignite or the flame around the burner is not uniform.	Verify that: The gas holes on the burner are not obstructed. Each of the burner's movable components is mounted correctly. There are no drafts near the cooking area.
The burner does not stay lit when the setting is "Low."	Verify that: The gas holes are not obstructed. There are no drafts present close to the cooking surface. The minimum has been appropriately modified (refer to section Gas Conversion)
The cookware is not stable.	Verify that: The cookware's bottom is perfectly flat. The cookware is appropriately centered on the burner. The support grids have not been inverted.

If, despite these checks, the gas hob still does not function properly and the problem persists, contact Brandt Customer Service Centre, and provide the following information:

- The nature of the issue.
 - The model number as displayed on the rating label
- Never employ technicians who are not authorized by Brandt or its service agent and refuse to accept non-original replacement parts.

GAS CONVERSION

- Take precautions on the operations and adjustments to be carried out when converting from one gas hob to another.
- **All work must be carried out by a Brandt authorized technician.**
- Before beginning, disconnect the gas and electrical supply to the appliance.

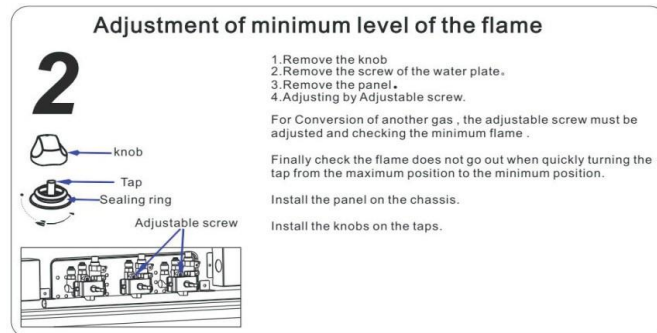
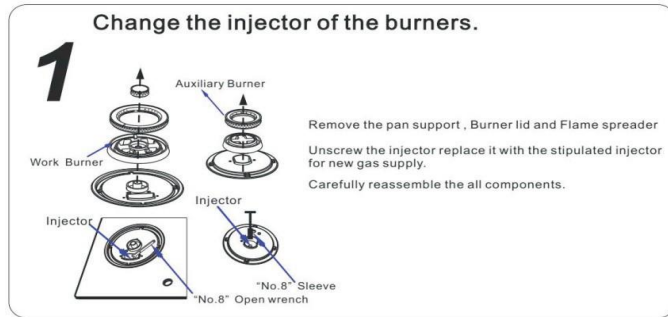

CAUTION!

- Do not disassemble the gas tap's shaft; in the event of a malfunction, replace the entire gas tap.
- Before replacing the burners on the gas hob, ensure that the injectors are not obstructed.
- After gas conversion a full operation and leak test (such as soap water or gas detector), must be performed.
- All conversions MUST be performed by Brandt-authorized technicians.

DESCRIPTION OF APPLIANCES

- Two or three burners with a stainless steel base plates are available on built-in gas hob ranges for LPG and Singapore Town Gas.
- Each burner, which is operated by a Flame Failure Device /plug-type gas valve, is controlled by metal control knobs located on the front of the tempered glass top, and each burner includes a Flame Failure Device (Thermocouple).
- The appliance's ignition system was powered by transformer 220V– 240V.
- The differences between the models are described in detail below: (Table 1)

Model Number	Burner Types (LPG-30mbar)		Total Power	Dimensions
	Wok Burners	Auxiliary Burner		
TG2282BEL	2	0	8.0kW(582g/h)	786mm x 450mm
TG2283BEL	2	1	9.5kW(691g/h)	786mm x 450mm
TG2293BEL	2	1	9.5kW(691g/h)	860mm x 500mm
Note:	Each Wok Burner is rated at 4.0kW Each Auxiliary Burner is rated at 1.5kW			

Model Number	Burner Types (TG-10mbar)		Total Power	Dimensions
	Wok Burners	Auxiliary Burner		
TG2282BEP	2	0	8.4kW	786mm x 450mm
TG2283BEP	2	1	10.0kW	786mm x 450mm
TG2293BEP	2	1	10.0kW	860mm x 500mm
Note:	Each Wok Burner is rated at 4.2kW Each Auxiliary Burner is rated at 1.6kW			

Burner	Injector size (mm)	Injector marking (mm)		Full rate kW
		Inner ring	Outer ring	
For LPG – 30mbar				
Wok	Inner ring	0.45	45	4.0 (291g/h)
	Outer ring	0.87	87	
Auxiliary		0.62	62	1.5 (109g/h)

For TG (G110) - 10mbar				
Burner	Injector size (mm)	Injector marking (mm)		Full rate kW
		Inner ring	Outer ring	
Wok	Inner ring	1.30	130	4.2
	Outer ring	2.30	230	
Auxiliary		1.75	175	1.6

Table 1

MAINTAINING YOUR COOKTOP

Before performing maintenance or cleaning on a gas appliance, disconnect it from the gas and 220-240Vac electricity supply. To prolong the life of the cooktop, it is essential that it be cleaned frequently and thoroughly, keeping in mind the following:

- Do not use steam cleaning equipment on the appliance.
- If there are enameled parts on the top, they must be cleaned with warm water and not with abrasive powders or corrosive substances that could damage them.
- The removable parts of the burners should be washed frequently with warm water and soap, making sure to remove caked on substances. Parts are to be dried thoroughly after cleaning.
- On cooktops with automatic ignition, the end of the electronic ignition device must be cleaned frequently to ensure that the gas holes do not become clogged.
- If stainless steel remains in prolonged contact with highly calcareous water or aggressive detergents (containing phosphorus), it can become discolored. It is advised that these parts be thoroughly rinsed with water and then dried thoroughly. In addition, it is recommended to clean up any spills.

Greasing the Taps

The gas taps may jam in time or they may become difficult to turn. If so, the tap itself must be replaced.

Caution: This operation must only be performed by a manufacturer-authorized technician

ELECTRICAL CONNECTION

- This appliance is designed for fixed wiring.
- This appliance must be earthed.
- This appliance is designed to be connected to a 220~240V, 50/60Hz AC electricity supply.
- The wires in the mains lead are coloured in accordance with the following code.
 - Green/yellow = Earth
 - Blue = Neutral
 - Brown = Live

! The wire which is coloured green and yellow must be connected to the terminal which is marked with the letter E or by the earth symbol. **⏚**

WIRING DIAGRAM

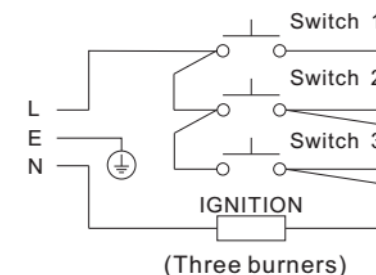
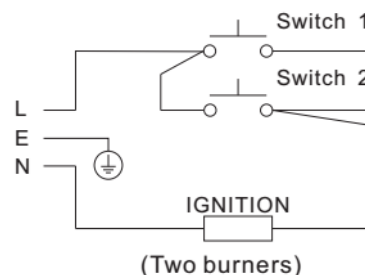

- when the power cord is damaged it must be replaced by the manufacturer to produce, customer service agent or similarly qualified personnel..

- Do not switch on/off any electrical appliance and do not touch any electric plug.

Warning

- This appliance shall be installed in accordance with regulations in force and only used in a well ventilated space.



- Prior to installation, ensure that the gas and electrical supply complies with the type stated on the rating plate.

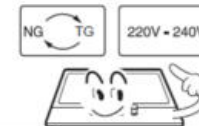

- The gas pipe and electrical cable must be installed in such a way that they do not touch any parts or the appliance.



LP Gas: Installation Instructions for Fixing Gas Cooker Elbow Joint

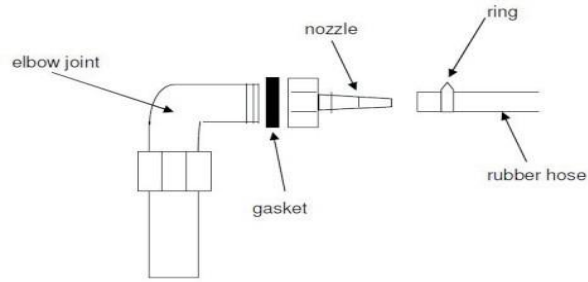

The gasket depicted above is to prevent gas leakage. After installation, turn on the gas supply and use soap solution (never use naked flame) to check for gas leakage.

Sharp edges are not allowed to contact the flexible tube. There shall be no internal connection between the cylinder compartment and the various parts of the appliance containing burners. The ventilation openings of the compartment cannot be blocked when the appliance is installed.

Gas connection to Non-flexible Pipe

The gas source must be connected to the appliance in a manner that does not create stress points in any component.

The appliance is fitted with an adjustable, "L" shaped connector and a gasket for the attachment to the gas supply. Should this connector have to be turned, if leakage is found after the connector assembled, please replace the gasket (supplied with appliance).

Check the Seal

Using a soapy water solution, ensure that all connections are properly sealed after the appliance has been installed. Never use open flame.

Caution!

- Prior to installation, ensure that the local distribution conditions (nature of the gas and gas pressure) and the appliance adjustment are compatible.
- The adjustment conditions for this appliance are listed on the rating label.
- This appliance is not connected to a combustion products evacuation device. It must be installed and wired in accordance with the current installation regulations. Particular attention must be paid to the ventilation requirements.

PRACTICAL ADVISE

For optimal performance, observe these guidelines:

- Use the correct cookware for each burner (refer to table below) to prevent the flame from reaching the pot or pan's sides.
- Always use flat-bottomed cookware and keep the lid on.
- When the contents reach a boil, reduce the heat to low.
- Do not use of cooking vessels on the hotplate that overlap its edges
- The device shall not be operated for more than 15 s. If after 15 s the burner has not lit, stop operating the device and open the compartment door and/or wait at least 1 min before attempting a further ignition of the burner.
- Prolonged intensive use of the appliance may call for additional ventilation, for example opening of a window, or more effective ventilation, for example increasing the level of mechanical ventilation where present.

Burner	Cookware Diameter
Wok Burners	24cm – 26cm
Auxiliary Burners	12cm – 22cm

EASE OF USE

On each control knob, the position of the corresponding gas burner is indicated. The burners vary in size and output. Choose the one that corresponds to the diameter of the used cookware.

Using the corresponding control knob, the burner can be adjusted to one of the following settings:

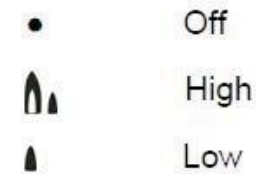

NOTE: A Crossbrace, also known as a Milk stand, is provided for small pot cooking for pot less than 12cm @ low flame.

To activate a burner





- Press the knob all the way in and turn it counterclockwise to the "high" setting. (On models equipped with safety devices, the user must hold down the knob until the burner ignites for approximately three seconds to allow the safety device to heat up.)

CAUTION: Caution: If the burner goes out by accident, turn off the gas using the knob and try to relight it after at least one minute.

To turn off a burner

- Turn the knob until it stops in the clockwise direction.

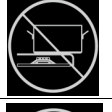
Symbol Description

Symbol 1		Do not place anything, e.g., flame tamer, asbestos mat, between pan and pan support as serious damage to the appliance may result.
Symbol 2		Do not remove the pan support and enclose the burner with a wok stand as this will concentrate and deflect the heat onto gas hob.
Symbol 3		Do not use large parts of heavy weights which can bend the pan support or deflect flame onto the gas hob.
Symbol 4		Locate pan centrally over burner so that it is stable and does not overheat the appliance.
Symbol 5		Use only wok support supplied or recommended by the manufacturer of the appliance.

INSTALLATION REQUIREMENT (FOR EXPORT MARKETS ONLY)

The following instructions are intended for the installer so that the installation and maintenance procedures may be carried out with the highest degree of professionalism and expertise.

Positioning

This appliance may only be installed and operated in rooms with permanent ventilation in accordance with current regulations and standards. The following condition must be met:

- The room must be equipped with a ventilation system that exhausts smoke and combustion gases to the exterior.
- This must be accomplished using a hood or electric ventilator that turns on automatically whenever the hood is activated.

The cylinder support shall have the following points:

- Must possess adequate mechanical strength.
- Not permitted to rest the cylinder directly on the ground.
- Not to exceed the height of the base on which the cylinder rests.
- The cylinder's regulator / tap must be easily accessible.
- The overflow of liquid from a gas hobs pan must not reach the cylinder or its accessories.

GAS CONNECTIONS

Gas Connection for Cooktop

An authorized installer is required to connect the cooktop to the gas supply. During the installation of this product, an approved gas tap must be installed in order to isolate the gas supply from the appliance for removal or maintenance purposes. The appliance must be connected to the gas mains or liquid gas tanks in accordance with the current safety standards and only after it has been determined that it is compatible with the type of gas to be used. If not, follow the instructions in the section titled, If the cooktop is to be connected to tanks containing liquid gas, use pressure regulators that meet current safety requirements.

Caution!

- The tube must not come into contact with sharp edges.
- There shall be no internal connection between the cylinder compartment and the various parts of the appliance where burners are located.
- When the appliance is in place, the ventilation openings of the compartment cannot be blocked.
- that the appliance operates safely, that the gas is properly regulated, and that your appliance lasts as long as possible, ensure that the gas pressure levels correspond to those indicated in Table 1.

Gas Connection to Flexible Steel Pipe

The appliance's gas feed connector is a threaded, male 1/2" connector for round gas pipe. Use only pipes, tubes, and gaskets that adhere to current safety standards. The length of the flexible pipes cannot exceed 2000mm. Upon completion of the connection, ensure that the flexible metal tube does not come into contact with any moving parts and is not crushed.

Installation above Ovens

If the cooktop is installed above a built-in oven, an insulating wood panel must be installed. This panel must be positioned approximately 50 mm from the bottom of the cooktop.

CAUTION!

When installing the cooktop above a built-in oven, the oven should be placed on two wooden strips; in the case of a joining cabinet surface, be sure to leave a 45mm x 560 mm space at the back. (Refer to Fig A.)

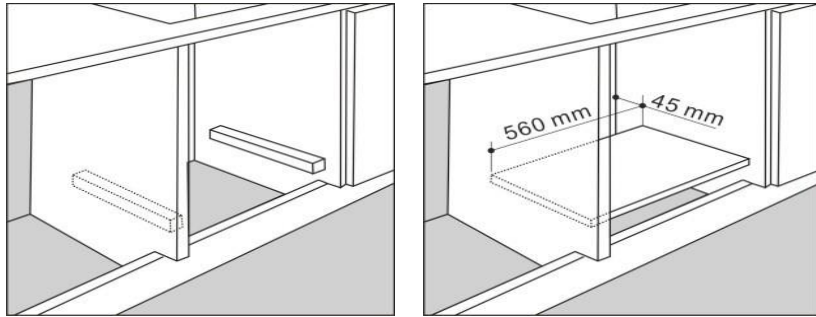

Fig A.

Fig B.

Installation with Gas Cylinder Compartments.

If the cooktop is installed above the cylinder compartment, an insulating wood panel must be installed. This panel must be positioned approximately 50 mm from the bottom of the cooktop. (Refer to Fig B.)

This compartment's opening must facilitate the insertion and removal of the cylinder. The opening and interior dimensions of the compartment must be at least large enough to accommodate the most used cylinders (with regulator installed) in the country. The total area of the opening in the upper portion of the compartment must be at least 1/100 of the floor area. The total area of the base's openings must be at least 1/50 of the compartment's floor area.

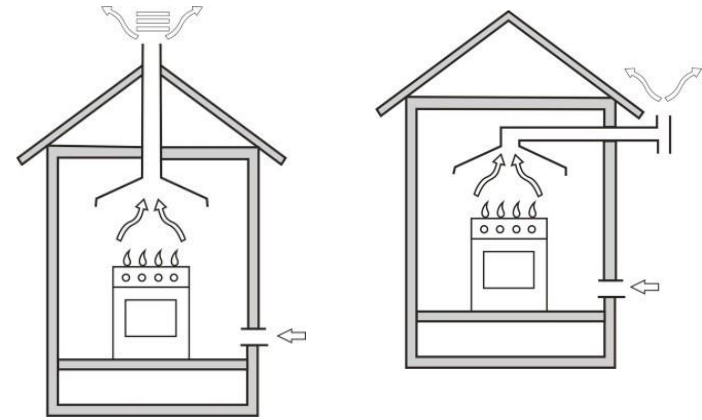

In a chimney or flue with multiple branches

Directly towards the exterior

- The space must also accommodate the airflow required for proper combustion. The combustion air flow rate cannot be less than 2 m³/h per kW of installed capacity. The supply of said air can be accomplished by direct influx from the exterior through a duct with an inner cross section of at least 100 cm² that cannot be accidentally obstructed.
- Those appliances that lack a safety device to prevent the flame from extinguishing by accident must have a ventilation opening that is double the size otherwise required, i.e. at least 200 cm² (Fig. A).
- Alternately, the room may be indirectly ventilated through adjacent rooms equipped with ventilation ducts to the exterior, as described above, so long as the adjacent rooms are not shared areas, bedrooms, or fire hazards (Fig. B).

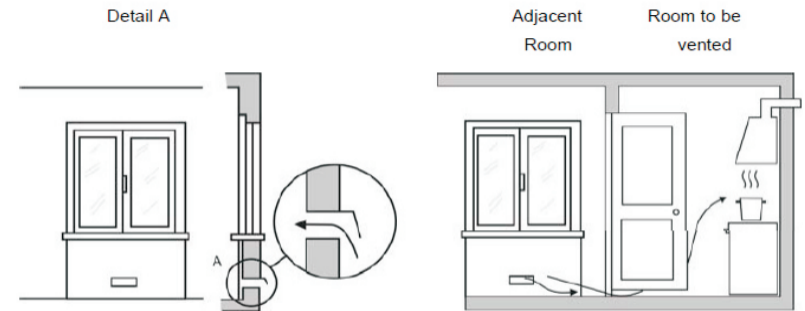

Examples of ventilation holes for comburent air.

Fig. A

Enlarging the ventilation slot between window and floor.

Fig. B

- Extensive and prolonged use of the appliance may require supplementary ventilation, such as opening a window or increasing the air intake system's power (if present)
- Liquefied petroleum gases (LPG) are heavier than air and as a result, settle downwards. Rooms in which LPG tanks are installed must be fitted with ventilation openings to the outside to allow the gas to escape in the event of a leak. Therefore, LPG tanks, whether empty or partially full, must not be installed or stored in rooms or spaces below ground level (cellars etc). It is also a good idea to keep only the tank currently being used in the room, making sure that it is not near sources of heat (ovens, fireplaces, stoves, etc.) that could raise the internal temperature of the tank above 50°C.

INSTALLATION PROCEDURE

The appliance can be installed alongside furniture units that are no taller than the height of the gas hob. The wall in direct contact with the gas hob back panel must be made of an inflammable material. During operation, the back panel of the gas hob could reach a temperature 50°C above room temperature. The following precautions must be taken to ensure proper installation of the stove:

- If the cabinets adjacent to the cooktop are taller than the gas hob itself, they must be installed at least 600 mm from the edge of the gas hob.
- Hoods must be installed according to the instructions in the installation manual for the hoods themselves, and at least 650 mm from the top of the grid support.
- The cabinets installed adjacent to the hood must be at least 420 mm from the ceiling. (Refer to Fig. C)
- Should a cooktop be installed directly beneath a cabinet, the top of the cabinet should be at least 720mm away.

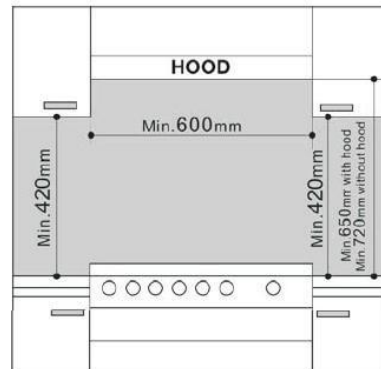

Fig. C

- To include distance to back wall - greater than 80mm; To include distance to left wall and right wall - greater than 100mm. (Refer to Fig. E)

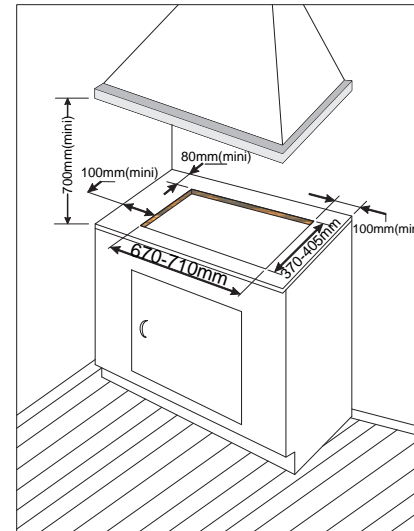

Fig. E

TG2282BE# / TG2283BE#

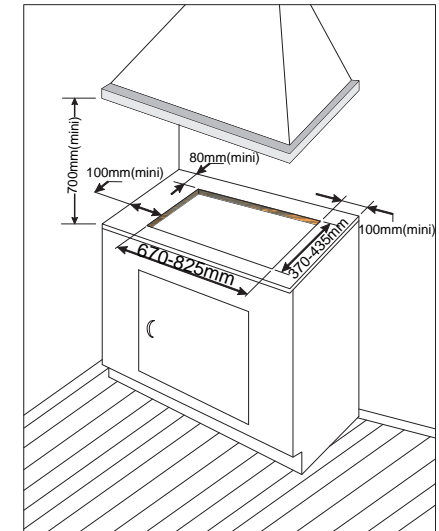
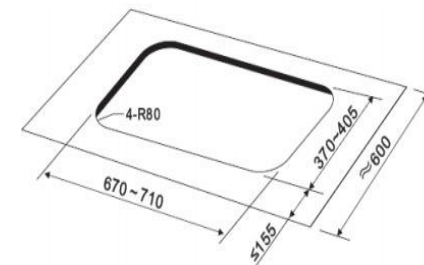

Fig. E

TG2293BE#

- The appliance cutout must conform to the specifications shown in figure D. Clamps are provided to secure the cooktop to countertops between 20mm - 60mm thick. To securely fasten the cooktop, it is recommended that all clamps be utilized.



155mm is from front of hob to the front of kitchen counter.

TG2282BE# / TG2283BE#

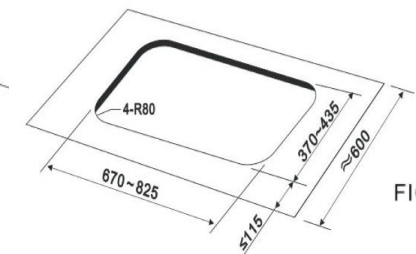

155mm is from front of hob to front of kitchen counter.

TG2293BE#

FIG. D